

Alternate Pathways to Higher Education

Foundation Studies Program

Coordinator: Mr David Potter

Dip Sec Ed (Avondale), BA (PUC), Grad Dip SLT (Massey), Grad Dip Ed Admin (Deakin) BEd (Avondale), MEdSt (UN), Cert IV Assessment and Workplace Training (Avondale)

Students who do not meet the normal entrance requirements may demonstrate that they have the potential to succeed in higher education by undertaking the Foundation Studies program and successfully completing the HEAccess Test. Students enrol in Avondale's Diploma of General Studies and normally undertake the HEAccess Test at the conclusion of the first semester. Upon successful completion of the first four subjects in the Foundation Studies program and the HEAccess Test, Australian and New Zealand students may apply to enrol in an undergraduate course.

International students also may choose Foundation Studies as a pathway to a degree course. Applicants from other countries whose first language is not English may be advised to take studies in Avondale's English Language program as a preparation for Foundation Studies. Depending on their prior level of achievement, international students enrol for either one semester, two semesters or two years.

Avondale's Foundation Studies program is designed to cater primarily for the following groups of people:

- 1 Students who have completed the final year of high school (eg, Year 12 Australia, Year 13 New Zealand) but whose Tertiary Entrance score did not permit entry to their desired course;
- 2 Persons of mature-age (normally over 19 years) who do not hold a Tertiary Entrance score;
- 3 Persons over 19 years of age whose first language is not English and whose English language proficiency score or level are likely to be a barrier to tertiary success;
- 4 Special groups of persons with whose institution or country a specially articulated pathway exists.

Prospective students may, of course, fall within one, two or more of these groups.

Subjects that form the core of the Foundation Studies program are:

- FS050.1/2 Foundation English
- FS052.1/2 Foundation Mathematics
- FS056.1/2 Tutoring English
- FS066.1.2 English Language Skills
- FS067.1/2 Academic Skills
- FS087.1/2 Intensive English I
- FS088.1/2 Intensive English II
- ED156.1/2 Communication and Information Management

CR011.1/2 Christian World View and Contemporary Life

CR143.1/2 Christian Studies I

Since Avondale College is a small institution, it is able to individualize students' programs to a certain extent, tailoring subjects to meet students' individual needs and selecting subjects that are appropriate for those needs. Students are interviewed and undertake a placement test in Week 1 of the semester and individual programs are constructed utilizing the Foundation Studies subjects that best meet their needs as indicated in the following examples:

HEAccess test

In most cases, students undertake the HEAccess Test at the completion of the four subjects undertaken in Semester 1. Those students who successfully complete that test are permitted to enter the undergraduate course of their choice, subject to demonstrating that they meet other course-specific prerequisites that may be in place.

Students who have completed four subjects in the Foundation Studies course but are unable to pass the HEAccess Test, may undertake a second semester of Foundation Studies by continuing their enrolment in the Diploma of General Studies and undertaking the following subjects and/or electives from the approved list.

Semester 1

Gr 1 School Leavers with borderline TE score (eg UAI 50–64)	100 level ¹ or FS050	100 level elective	100 level elective	100 level elective
Gr 2 School Leavers with low TE score (eg UAI 30–49)	FS050	FS067	FS066 or elective	CR011
Gr 3 School Leavers with learning difficulties	Normally FS050	FS067	FS066 or elective	CR011
Gr 4 Mature-aged	FT050	FS067	FS066 or elective	CR011
Gr 5 ESL ²	FS050	FS067	FS066	FS066
Gr 6 Special Articulations ³	FS050	FS067	FS066 or elective	CR011

Semester 2

Gr 1 School Leavers with borderline TE score (eg UAI 50–64)	ED156	100 level elective	100 level elective	100 level elective
Gr 2 School Leavers with low TE score (eg UAI 30–49)	ED156	CR143	100 level elective	100 level elective
Gr 3 School Leavers with learning difficulties	ED156	CR143	100 level elective	100 level elective
Gr 4 Mature-aged	ED156	CR143	100 level elective	
Gr 5 ESL ⁴	FS087	FS088	FCR143 or CR011	
Gr 6 Special Articulations ⁵	ED156	100 level elective	100 level elective	100 level elective

NOTES

- 1 A list of subjects approved as 100 level electives is included in Table 1
- 2 Students who do not have an IELTS score of 6 (6.5 for nursing) may be advised to undertake the ELICOS program prior to undertaking the Foundations Studies program.
- 3 For example, Singapore students from San Yu Adventist High School.
- 4 Students who do not have an IELTS score of 6 (6.5 for nursing) may be advised to undertake the ELICOS program prior to undertaking the Foundations Studies program.
- 5 For example, Singapore students from San Yu Adventist High School.

Table 1

List of 100-level Electives

AC160	Introduction to Accounting A
AC162	Introduction to Accounting B
CC160	Media Interpretations
CC161	Introductory Journalism
CH163	General Chemistry
CO164	Introduction to Information Management
CO168	Introduction to Programming
CR243	Christian Faith II
CY165	SDA History and Ministry of Ellen White
GE180	Environmental Issues
GE190	Global Issues
HI163	Australia: Prehistory to Present
HI164	The Ancient World
HP143	Fitness and Food for Health
HP144	Biomechanics for Physical Educators
HP161	Food, Nutrition and Health
MA163	Business Statistics
MA164	General Mathematics
MS100	Performance and Music Skills 1A
MT145	Organisations in Business Context
NT160	Gospels A
NT161	Gospels B
PS165	General Psychology
PS110	Introductory Psychology and Sociology
SC150	Health Science II
VC120	Painting and Drawing I
VA123	Photography and Sculpture
VC130	3D Studies
VC140	Design Principles and Practice

Alternate Pathways to Higher Education

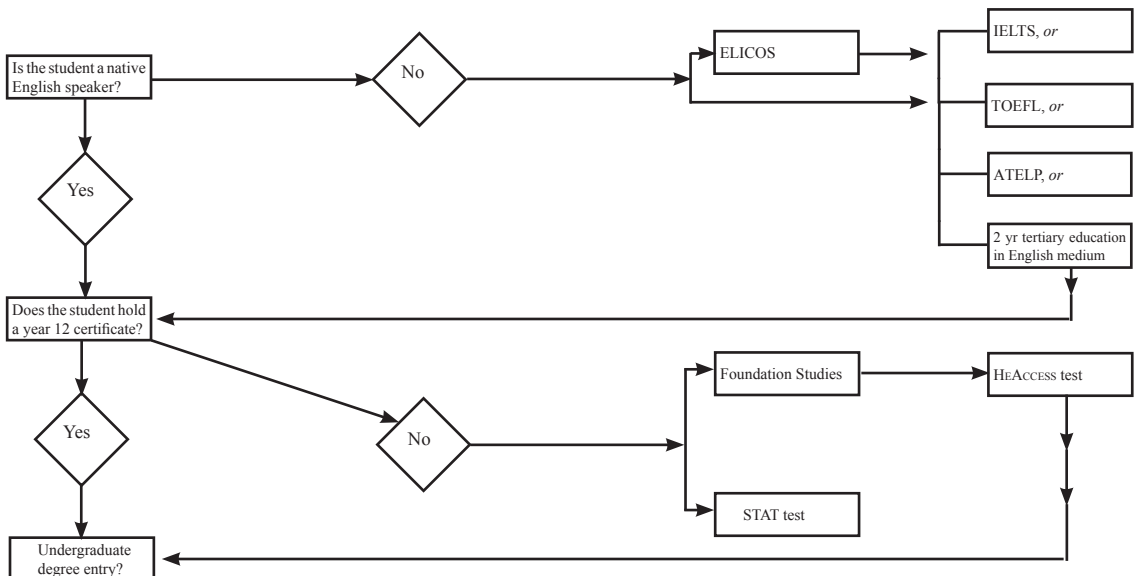

Synopses of Foundation Studies Subjects

FS050.1/2 Foundation English

6 cr pts

This subject is a general education subject, providing opportunity for students to develop the formal communication skills needed for tertiary study. The main focus is writing, including the preparation and presentation of a reading research essay. This is supported by an emphasis on critical thinking. Students are given opportunity to increase their understanding of significant human issues by thinking and writing about them.

FS052.1/2 Foundation Mathematics

6 cr pts

This subject aims to give students a basic understanding of the mathematical skills required to continue with further tertiary education involving mathematics. In this class students become familiar with some of the most fundamental branches of mathematics, including: algebra, geometry, trigonometry, statistics and more.

FS056.1/2 Tutoring English

6 cr pts

This subject is a general education subject, providing opportunity for students who have difficulty with English, including those with learning difficulties (or a language deficit) affecting their reading and writing, to improve their English language competency.

FS066.1.2 English Language Skills

6 cr pts

This is a course in English for academic purposes. The subject provides opportunity for students from a non-English speaking background (NESB) and native English speakers with a communication skills deficit to improve their English language competency.

FS067.1/2 Academic Skills

6 cr pts

This subject looks at aspects of learning, particularly metacognition and study skills, and assists students in managing a study program. It also enables them to develop the keyboarding and word processing skills needed for further study at Avondale. Personalised tutoring assistance, designed to provide general academic support, is incorporated into the program.

CR011 Christian World View and Contemporary Life

6 cr pts

This subject aims, from the perspective of Christian faith, to increase students' awareness of their own worldview and respect for the worldviews of others.

ED156 Communication and Information Management

6 cr pts

This general education subject develops skills in communication and information management necessary for students embarking on a higher education course. The communication module focuses on skills in communication including interpersonal communication skills, academic skills for the lecture room, and the writing of essays and other assignments. The information management module focuses on skills in the use of word processing,

presentation, spreadsheet, and database software. Both modules will be offered at introductory and advanced levels, and, depending on prior learning and expertise, students may undertake both modules at the introductory level, both at the advanced level, or one at each level.

FS087.1/2 Intensive English I

6 cr pts

This subject covers English for academic purposes for students whose first language is not English. It enables students to improve their English language competency through a range of in-class and out-of-class activities that give opportunity for the development of communication skills, particularly reading and writing.

FS088.1/2 Intensive English II

6 cr pts

Extending the language skills acquired in Intensive English I, this subject further develops students English language skills for academic purposes for students whose first language is not English. It enables students to improve their English language competency through a range of in-class and out-of-class activities that give opportunity for the development of communication skills, particularly reading and writing.

CR143.1/2 Christian Studies I

6 cr pts

This subject focuses on the dynamics and experience of salvation, the spiritual message of the Bible and the implications for Christian belief and lifestyle response. The emphasis throughout is on relating the study of Christian faith to the life issues and concerns of the student.

English Language Programs

Coordinator: Mr David Potter

Dip Sec Ed (Avondale), BA (PUC), Grad Dip
SLT (Massey), Grad Dip Ed Admin (Deakin) BEd
(Avondale), MEdSt (UN), Cert IV Assessment and
Workplace Training (Avondale)

Staff

Lecturers

David Potter

BA, DipSecEd, BEd, GradDip(SLT), GradDip(Ed Admin),
MEdStud, Cert IV Assessment and Workplace Training,
MEd (TESOL)

*Director, English Language Centre and Director of Studies,
ELICOS*

Gay Grillmeier

TchCert, BEd(Sec), BA, MA, DipAdvCounsellor,
PostGradCertDes&Tech, PostGradCert(TESOL)

Lana Hibbard

BEd, GradDipEdStud(TESOL), MEd(TESOL specialisation),
PhD Candidate

Diane Hillsdon

DipTchPrim, BEd(Prim), MA(TESOL)

Lyn Medhurst

BEd, GradDip(TESOL), MEd

ELICOS Courses

The Avondale ELICOS program offers 10-week English language courses (each divided into two five-week modules) at four levels:

EL081	Elementary ELICOS, Part I
EL082	Elementary ELICOS, Part II
EL083	Intermediate ELICOS, Part I
EL084	Intermediate ELICOS, Part II
EL085	Upper-intermediate ELICOS, Part I
EL086	Upper-intermediate ELICOS, Part II
EL087	Advanced ELICOS, Part I
EL088	Advanced ELICOS, Part II

Courses begin every five weeks. These courses enable students to develop their English language competency and performance. They provide opportunity for students to improve their listening, speaking, reading and writing skills. Successful completion of Advanced ELICOS enables students to apply to enter Avondale degree courses. The ELICOS program runs for 45 weeks of the year, beginning in the first week of January and ending the week before Christmas, with several short breaks through the year.

The Avondale ELICOS program is regulated by NEAS, the national accrediting body for the ELICOS industry. All the teaching staff have TESOL degrees and are experienced English teachers.

IELTS—International English Language Testing Service

IELTS is the standard test of English for overseas students who intend to study in Australia, Canada, New Zealand and the United Kingdom. IELTS assesses a candidate's ability to read, write, speak and listen in English. Avondale ELICOS students can opt to take an IELTS test upon completion of their course. Those intending to commence a nursing degree are required to obtain an IELTS score of 6.5, with no individual band below 6.0. This is a requirement of the Nurses Registration Board.

ATELP—Avondale Test of English Language Proficiency

ELICOS students who wish to progress into an Avondale bachelor degree course will need to demonstrate their proficiency in English. This may be by an IELTS test taken at an official IELTS test centre, or the Avondale Test of English Language Proficiency (ATELP). The ATELP will test reading, writing, listening and speaking skills in English. The test will be offered by the Avondale English Language Centre four times a year. Students who wish to take the test at other than the specified times will be charged a fee.

Bridging Programs

BR010.1/2 Academic Bridging Program

A 20-hour program normally conducted over four days in the week prior to the commencement of each semester. The program provides an introduction to tertiary skills such as goal-setting, learning styles, time management, stress management, learning and memory, clear thinking, reading skills, writing skills, using the library, note-taking in lectures/seminars, common forms of assessment. The program is designed as a link to tertiary study for those returning after a period of absence, international students for whom English is not their first language and others in need of such an introductory program.

BR020.1 Chemistry Bridging Course

A one-week, full-time introduction to the principles, theory and practice of Chemistry. Topics include: atomic structure, ionic and covalent compounds, solutions, units of measurement, states of matter, energy and temperature, and properties of matter.

HA060.1 Foundations of Harmony

An introduction to the fundamentals of music theory, harmonic structures and chord progressions. This course is designed to revise all aspects of music theory, aural skills and practical that will be assumed knowledge in the music major or minor of a BA, BA/BBus or BA/BTch degree.

This bridging subject does not form part of the specialisation, major or minor in Music, nor can it be counted towards an Avondale degree.

WP010.1/2 Word Processing Competency

This program is designed to improve students' competency in typing skills, computer skills, and word processing skills necessary for typing assignments and other academic documents required in higher education.