

# Alternative Pathways to Higher Education

## Diploma of General Studies

Coordinator: Mr David Potter

Dip Sec Ed (Avondale), BA (PUC), Grad Dip SLT (Massey), Grad Dip Ed Admin (Deakin) BEd (Avondale), MEdSt (Ncle), MED TESOL, Deakin, Cert IV Assessment and Workplace Training (Avondale)

Students who do not meet the normal degree entrance requirements may qualify to enter a degree program by demonstrating satisfactory performance in the diploma.

Depending on their prior level of achievement, international students enrol for either one semester, two semesters or two years.

Avondale College's Diploma of General Studies program is designed to cater primarily for the following groups of people:

- 1 Students who have completed the final year of high school (eg, Year 12 Australia, Year 13 New Zealand) but whose Tertiary Entrance score did not permit entry to their desired course;
- 2 Persons of mature-age (normally over 19 years) who do not hold a Tertiary Entrance score;
- 3 Persons over 19 years of age whose first language is not English and whose English language proficiency score or level are likely to be a barrier to tertiary success;
- 4 Special groups of persons with whose institution or country a specially articulated pathway exists.

Prospective students may, of course, fall within one, two or more of these groups.

Subjects that form the core of the Diploma of General Studies program are:

- FS050.1/2 Foundation English
- FS052.1/2 Foundation Mathematics
- FS056.1/2 Tutoring English
- FS066.1.2 English Language Skills
- FS067.1/2 Academic Skills
- FS087.1/2 Intensive English I
- FS088.1/2 Intensive English II
- ED156.1/2 Communication and Information Management
- CR081.1/2 Christian World View and Contemporary Life
- ED143.1/2 Christian Studies for Teachers

Since Avondale College is a small institution, it is able to individualize students' programs to a certain extent, tailoring subjects to meet students' individual needs and selecting subjects that are appropriate for those needs. Students are interviewed and undertake a placement test in Week 1 of the semester and individual programs

are constructed utilizing the Diploma of General Studies subjects that best meet their needs as indicated in the following examples:

### Semester 1

Gr 1 School Leavers with borderline TE score (eg UAI 50–64)	100 level <sup>1</sup> or FS050	100 level elective	100 level elective	CR081 or CR143
Gr 2 School Leavers with low TE score (eg UAI 30–49)	FS050	FS067	FS066 or elective	CR081
Gr 3 School Leavers with learning difficulties	Normally FS050	FS067	FS066 or elective	CR081
Gr 4 Mature-aged	FS050	FS067	FS066 or elective	CR081
Gr 5 ESL <sup>2</sup>	FS050	FS067	FS066	FS087
Gr 6 Special Articulations <sup>3</sup>	FS050	FS067	FS066 or elective	CR081

### Semester 2

Gr 1 School Leavers with borderline TE score (eg UAI 50–64)	100 level elective	100 level elective	100 level elective	100 level elective
Gr 2 School Leavers with low TE score (eg UAI 30–49)	100 level elective	CR143	100 level elective	100 level elective
Gr 3 School Leavers with learning difficulties	100 level elective	CR143	100 level elective	100 level elective
Gr 4 Mature-aged	100 level elective	CR143	100 level elective	
Gr 5 ESL <sup>4*</sup>	FS087	FS088	CR143 or CR081	
Gr 6 Special Articulations <sup>5*</sup>	100 level elective	100 level elective	100 level elective	100 level elective

\* Second semester for ESL students generally involves repeating FS050 and FS066 in practice

### NOTES

- 1 A sample list of subjects suitable as 100-level electives is included in Table 1
- 2 Students who do not have an IELTS score of 6 (6.5 for nursing) may be advised to undertake an ELICOS program prior to undertaking the Diploma of General Studies program.
- 3 For example, Singapore students from San Yu Adventist High School.
- 4 Students who do not have an IELTS score of 6 (6.5 for nursing) may be advised to undertake an ELICOS program prior to undertaking the Diploma of General Studies program.
- 5 For example, Singapore students from San Yu Adventist High School.

**Table 1**

**Sample List of 100-level Electives**

AC160	Introduction to Accounting A	MA163	Business Statistics
AC162	Introduction to Accounting B	MA164	General Mathematics
CC160	Media Interpretations	MS100	Performance and Music Skills 1A
CC161	Introductory Journalism	MT145	Organisations in Business Context
CH163	General Chemistry	NT160	Gospels A
CO164	Introduction to Information Management	NT170	New Testament Epistles A
CO168	Introduction to Programming	PS165	General Psychology
CY165	SDA History and Ministry of Ellen White	PS119	Introductory Psychology and Sociology
GE180	Environmental Issues	SC148	Health Science II
GE190	Global Issues and Humanitarian Response	VC120	Painting and Drawing I
HI163	Australia: Prehistory to Present	VC123	Photography and Sculpture
HI164	The Ancient World	VC130	3D Studies
HP143	Fitness and Food for Health	VC140	Design Principles and Practice
HP144	Biomechanics for Physical Educators		
HP161	Food, Nutrition and Health		

**Alternative Pathways to Higher Education**

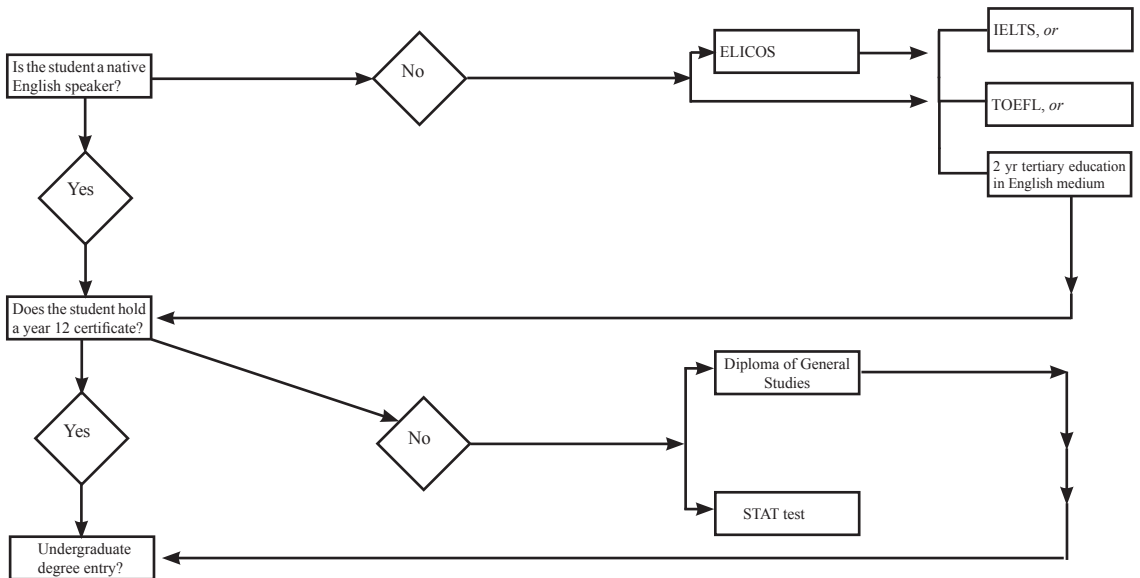

## Synopses of Foundation Studies Subjects

### **ED143.1/2 Christian Studies for Teachers 1 6 cr pts**

This subject focuses on the dynamics and experience of salvation, the spiritual message of the Bible and the implications for Christian belief and lifestyle response. The emphasis throughout is on relating the study of Christian faith to real life issues and to the concerns of the student.

### **FS050.1/2 Foundation English 6 cr pts**

This subject is a general education subject, providing opportunity for students to develop the formal communication skills needed for tertiary study. The main focus is writing, including the preparation and presentation of a reading research essay. This is supported by an emphasis on critical thinking. Students are given opportunity to increase their understanding of significant human issues by thinking and writing about them.

### **FS052.1/2 Foundation Mathematics 6 cr pts**

This subject aims to give students a basic understanding of the mathematical skills required to continue with further tertiary education involving mathematics. In this class students become familiar with some of the most fundamental branches of mathematics, including: algebra, geometry, trigonometry, statistics and more.

### **FS056.1/2 Tutoring English 6 cr pts**

This subject is a general education subject, providing opportunity for students who have difficulty with English, including those with learning difficulties (or a language deficit) affecting their reading and writing, to improve their English language competency.

### **FS066.1.2 English Language Skills 6 cr pts**

This is a course in English for academic purposes. The subject provides opportunity for students from a non-English speaking background (NESB) and native English speakers with a communication skills deficit to improve their English language competency.

### **FS067.1/2 Academic Skills 6 cr pts**

This subject looks at aspects of learning, particularly metacognition and study skills, and assists students in managing a study program. It also enables them to develop the keyboarding and word processing skills needed for further study at Avondale College. Personalised tutoring assistance, designed to provide general academic support, is incorporated into the program.

### **CR081 Christian World View and Contemporary Life 6 cr pts**

This subject aims, from the perspective of Christian faith, to increase students' awareness of their own worldview and respect for the worldviews of others.

### **ED156 Communication and Information Management 6 cr pts**

This general education subject develops skills in communication and information management necessary

for students embarking on a higher education course. The communication module focuses on skills in communication including interpersonal communication skills, academic skills for the lecture room, and the writing of essays and other assignments. The information management module focuses on skills in the use of word processing, presentation, spreadsheet, and database software. Both modules will be offered at introductory and advanced levels, and, depending on prior learning and expertise, students may undertake both modules at the introductory level, both at the advanced level, or one at each level.

### **FS087.1/2 Intensive English I 6 cr pts**

This subject covers English for academic purposes for students whose first language is not English. It enables students to improve their English language competency through a range of in-class and out-of-class activities that give opportunity for the development of communication skills, particularly reading and writing.

### **FS088.1/2 Intensive English II 6 cr pts**

Extending the language skills acquired in Intensive English I, this subject further develops students English language skills for academic purposes for students whose first language is not English. It enables students to improve their English language competency through a range of in-class and out-of-class activities that give opportunity for the development of communication skills, particularly reading and writing.

### **CR143.1/2 Christian Studies I 6 cr pts**

This subject focuses on the dynamics and experience of salvation, the spiritual message of the Bible and the implications for Christian belief and lifestyle response. The emphasis throughout is on relating the study of Christian faith to the life issues and concerns of the student.

## **Bridging Programs**

### **BR010.1/2 Academic Bridging Program**

A 20-hour program normally conducted over four days in the week prior to the commencement of each semester. The program provides an introduction to tertiary skills such as goal-setting, learning styles, time management, stress management, learning and memory, clear thinking, reading skills, writing skills, using the library, note-taking in lectures seminars, common forms of assessment. The program is designed as a link to tertiary study for those returning after a period of absence, international students for whom English is not their first language and others in need of such an introductory program.

### **BR020.1 Chemistry Bridging Course**

A one-week, full-time introduction to the principles, theory and practice of Chemistry. Topics include: atomic structure, ionic and covalent compounds, solutions, units of measurement, states of matter, energy and temperature, and properties of matter.

### **HA060.1 Foundations of Harmony**

An introduction to the fundamentals of music theory, harmonic structures and chord progressions. This course is designed to revise all aspects of music theory, aural skills and practical that will be assumed knowledge in the music major or minor of a BA, BA/BBus or BA/BTch degree.

*This bridging subject does not form part of the specialisation, major or minor in Music, nor can it be counted towards an Avondale College degree.*

### **WP010.1/2 Word Processing Competency**

This program is designed to improve students' competency in typing skills, computer skills, and word processing skills necessary for typing assignments and other academic documents required in higher education.